

FIRSTLANE

SPEED GATES

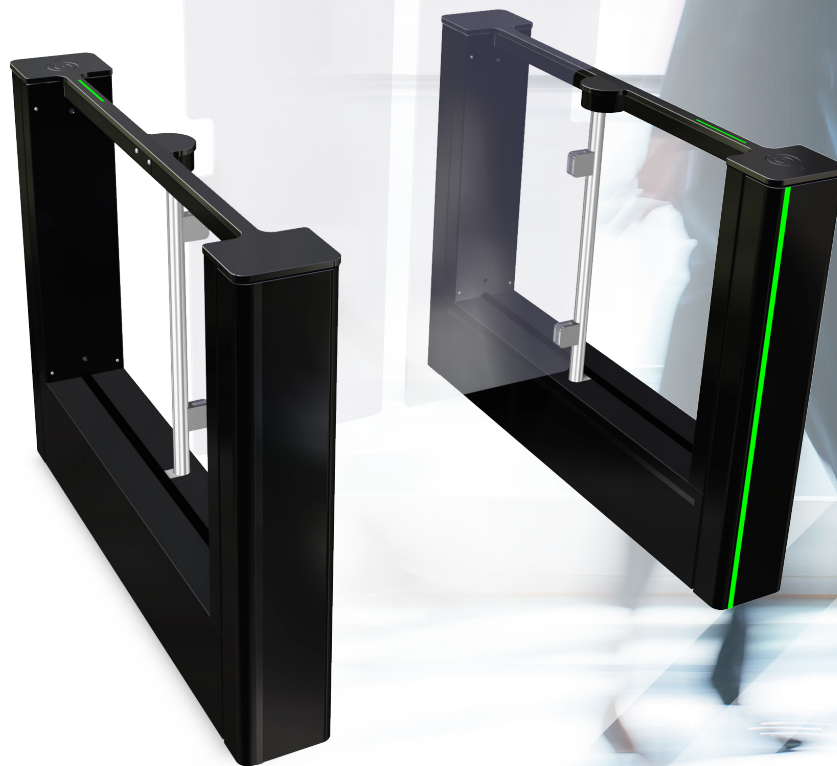

AS AUTOMATIC
SYSTEMS

Leading the way to future
safety and security

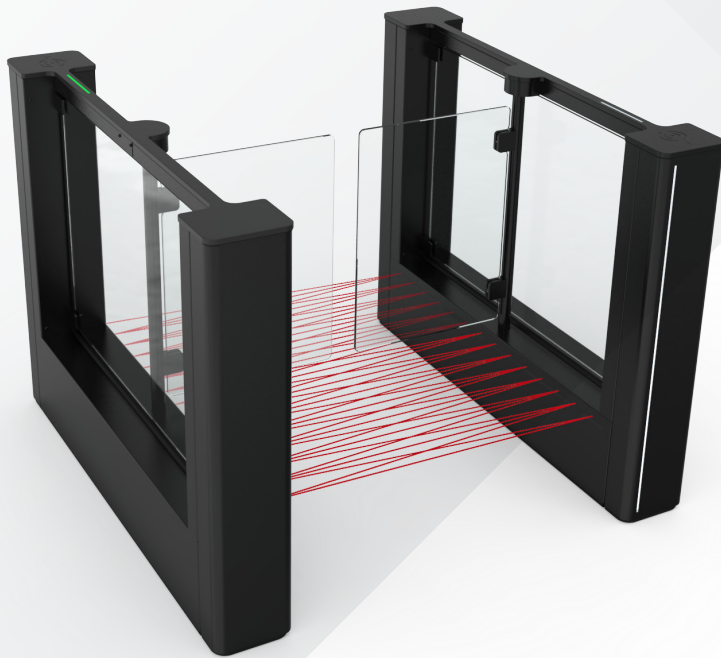

-  SECURITY
-  SAFETY
-  PASSAGE THROUGHPUT
-  CONNECTIVITY
-  WIND-RESISTANT



STYLISH & ARCHITECTURAL TRENDS



INTUITIVE USER EXPERIENCE



QUALITY OF BUILD, RELIABILITY & SERVICE



INNOVATIVE TECHNOLOGIES

SECURITY

BEST IN CLASS FOR THROUGHPUT AND DETECTION THANKS TO OUR PROPRIETARY DIRAS DETECTION SYSTEM

- High-density matrix of infrared beams follows users' progression through the lane.
- Dynamic and predictive algorithms ensure fraud detection: tailgating, piggybacking,

MULTIPLE INTEGRATION CAPABILITIES (OPTIONAL)

The cabinet design provides space to integrate authentication peripherals including but not limited to:

- RFID, QRcode and barcodes readers
- Biometric devices

MARKETS

- Office buildings, head offices and administrative sites
- Schools, universities and colleges
- Gyms and fitness centres
- Government buildings and institutions
- Stadiums & Museums

AESTHETICS

- Modern and stylish look
- Dynamic pictograms for an intuitive user experience
- Laminate top cover with RFID logo(s), and function light(s).



FIRSTLANE High Glass Obstacles

- Passage widths: 24 3/16" (584 mm) or 36" (915 mm)
- Glass heights: 47 1/4" (1200 mm) / 59 1/16" (1500 mm) / 66 15/16" (1700 mm) / 70 7/8" (1800 mm)

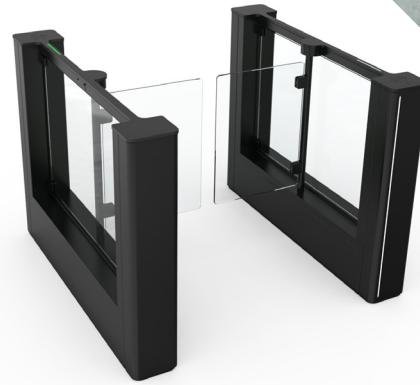

FIRSTLANE Low Glass Obstacles

- Passage widths: 24 3/16" (584 mm) or 36" (915 mm)
- Glass height: 35 7/16" (900 mm)

FFirstLane PLUS



FIRSTLANE PLUS > Outdoor High Aero Obstacles

- Passage widths: 24 3/16" (584 mm) or 36" (915 mm)
- Aero height: 68 7/8" (1750 mm)



FIRSTLANE PLUS > Outdoor Low Aero Obstacles

- Passage widths: 24 3/16" (584 mm) or 36" (915 mm)
- Aero height: 35 3/4" (908 mm)

STANDARD FIRSTLANE DIMENSIONS

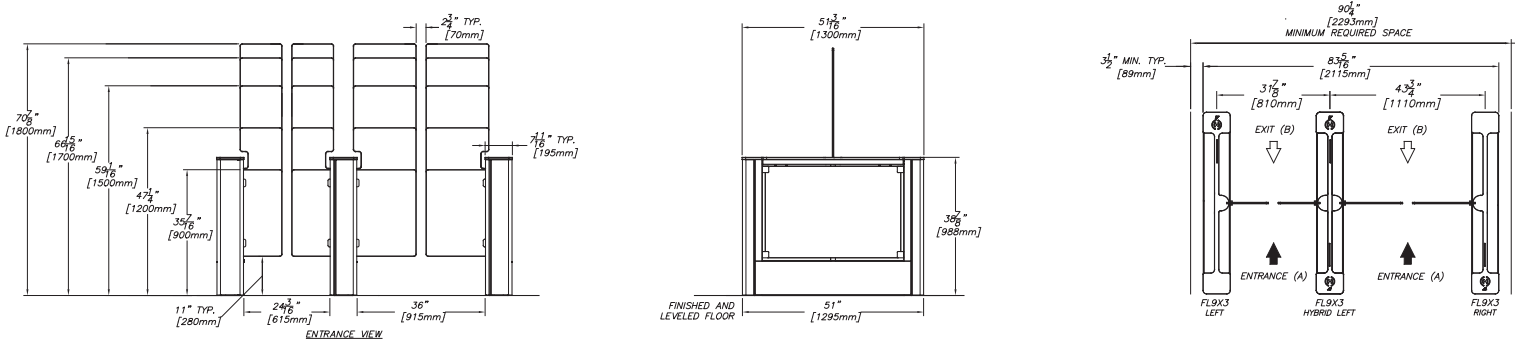

STANDARD FIRSTLANE PLUS DIMENSIONS

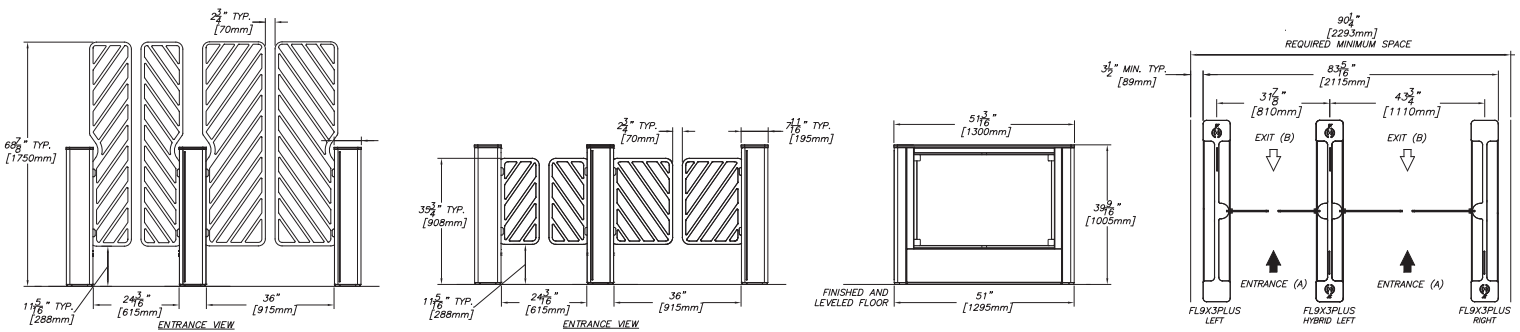

Contact us for more information regarding the ASLYNK™, monitoring and control interface for AUTOMATIC SYSTEMS pedestrian and vehicle equipment.

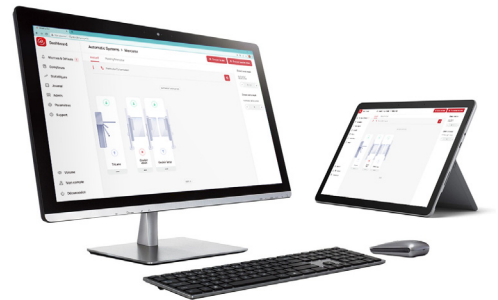

AUTOMATIC SYSTEMS

1-800-263-6548

www.automatic-systems.us

www.automatic-systems.ca