

SLIM940

Technical datasheet

NAM-SLIM940-FT-EN-X

SlimLane



AS1 AUTOMATIC SYSTEMS

Access controlled...

Future secured

DESCRIPTION

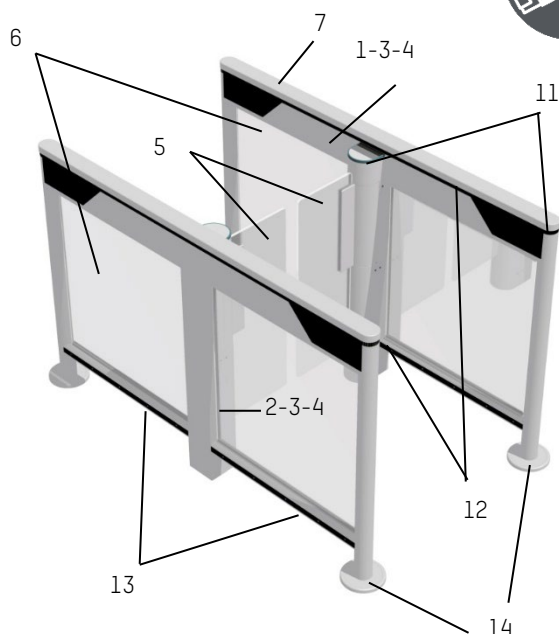

- 1. Handrail frame:** steel beam with RoHS anti-corrosion zinc plating treatment and stainless-steel end posts. The handrail includes photoelectric cells for user detection and the logic control board.
- 2. Self-supporting kinematic steel frame** with RoHS anti-corrosion zinc plating treatment. The frame contains the swinging obstacle electromechanical drive assembly and the electronic control boards.
- 3. Brushed #4 AISI 304L stainless steel housing.**
- 4. Brushed #4 AISI 304L stainless steel panels** fastened to the frame, giving access to the internal components.
- 5. Clear, 3/8 in (9.5 mm) thick tempered monolithic glass obstacles**, swinging in the direction of user passage.
- 6. Clear, 1/4 in (6 mm) thick tempered glass side panels.**
- 7. Brushed #4 AISI 304L stainless steel top cover.**
- 8. Electromechanical drive unit consisting of:**
 - A DC permanent magnet motor with an epicyclic gearbox.
 - A controller which provides progressive accelerations and decelerations of the obstacles, for smooth movement and enhanced user safety.
 - A geared electromagnetic brake for locking of the obstacles in the event of a forced entry attempt.
 - An optical encoder to monitor the obstacles position.
 - EGRESS standard operating mode: obstacles open in the direction of egress with a simple push.
 - Supercapacitor circuit board for automatic opening in the egress direction in case of power failure.
- 9. AS1190 logic control board**, equipped with ARM 9 technology and Linux operating system, ensuring advanced traffic management. An embedded web server, accessible through a web browser, offering an interface for the configuration of the gate's functional parameters, as well as a complete diagnostic and maintenance tool.
- 10. Transfer of information through an Ethernet interface**, USB and dry contacts: passage authorization, passage information, reader locking, fraud, equipment failure, etc.
- 11. Static orientation and function pictograms** indicating gate and passage status to the user.
- 12. Proprietary DIRAS detection system**, consisting of a high-density matrix of infrared transmitter/receiver photocell beams. It follows users' progression through the lane, as well as ensuring their safety during opening/closing of the obstacles.
- 13. Enhanced electronic protection and luggage detection cells** (A and B directions).
- 14. Finishing plate for end posts.**

The **SlimLane 940** double swing door security entrance lane offers a high bidirectional throughput and uncompromising security.

With its transparent, elegant design and minimal footprint, the **SlimLane 940** is designed to fit perfectly into any architectural style.

Equipped with high processing capacity and an exclusive detection system, the **SlimLane 940** guarantees accurate user tracking and prevents any unauthorized use.

The **SlimLane 940** is a modular product that can be installed as a single lane, or in a multi-lane array. It can be combined with the **SlimLane 950** wide lane as well as with single swing door units, such as the **SlimLane 944**.

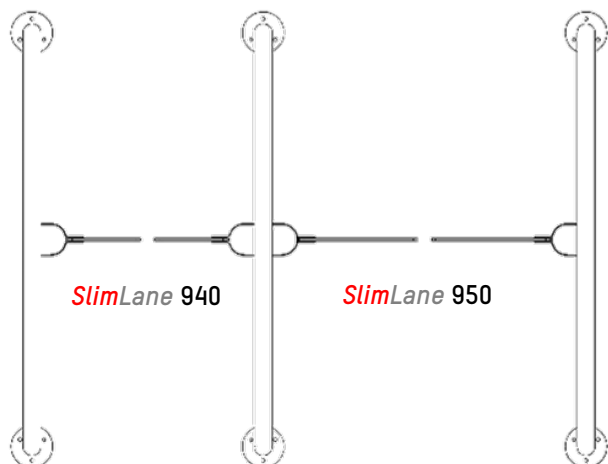



STANDARD TECHNICAL CHARACTERISTICS

Electrical Requirements	15A @ 24 VDC 6A @ 120 VAC (optional)
Power Rating	40 W (at rest) 300 W (nominal) 480 W (peak)
Motor	24 VDC – 93 W
Passageway (W)	23 in (584 mm)
Min. opening and closing times	0.7 to 1.2 s (Depending on the access control system reactivity and the speed of users)
Installation Environment (Indoor Use Only)	Ambient temp: 32 to 122°F (0 to +50°C) Ambient humidity: Less than 95%RH (No condensing allowed)
Noise Level	55 dB (at two feet from the motor)
Net Weight	137 lbs (62 kg) (per left/right unit) 201 lbs (91 kg) (per intermediate unit)
IP Rating	40
Certification	 As per UL 2593, File E197818

PRECAUTIONS FOR USE

- For security reasons, children (users smaller than 39" tall) must be supervised at all times by an adult when in the vicinity of the unit and during passage through the lane.
- A child must absolutely precede the accompanying adult.

 Please refer to the project specific installation drawings provided.

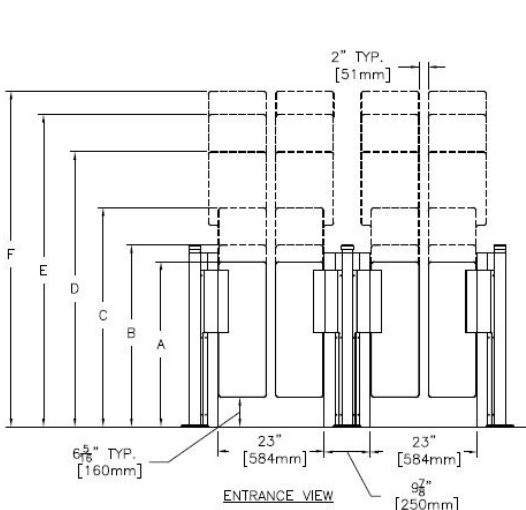

OBSTACLE HEIGHT		
A	35 ⁷ / ₁₆ " [900mm]	STD
B	39" [991mm]	OPT
C	47" [1194mm]	OPT
D	59" [1499mm]	OPT
E	67" [1702mm]	OPT
F	72" [1829mm]	OPT

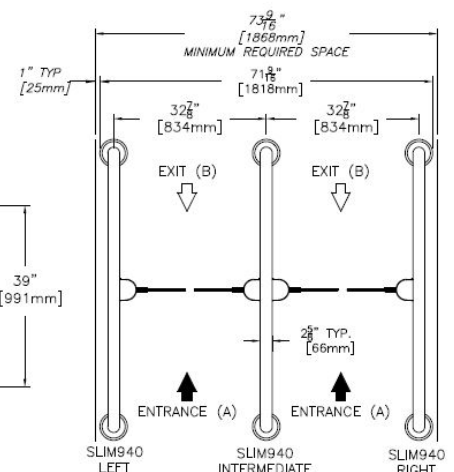
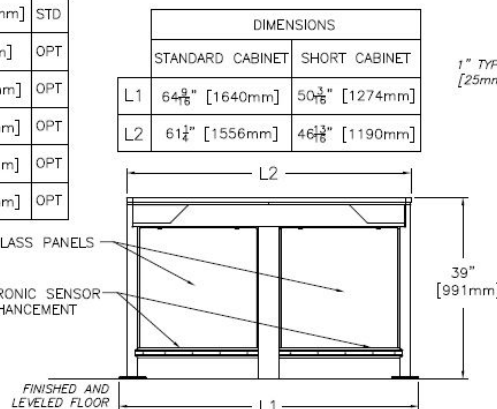

OPTIONS

- 120 VAC Power supply.
- SECURI-SAFE operating mode: electromechanical locking of the obstacles in case of a forced entry attempt, in any passage direction.
- High glass obstacle options available: 39" [991mm], 47" [1194mm], 59" [1499mm], 67" [1702mm] and 72" [1829mm].
- Standard reader integration within housing*.
- Standard support bracket for surface mounted reader integration.
- Barcode reader integration*.
- Custom top cover.
- Customized logo on obstacle.
- Raised bases*.
- Ramps*.
- Monitoring panel (*Smart & Slim*, *Smart Touch* or the Push Button Control Panel).
- Connectivity kit for Ethernet connection of one or more lanes to the network.
- Short cabinet version "SC".
- Flangeless (on both end posts).
- Extended end posts (EP, EPW, EPR) *.
- LED lighting for the side glass panels.
- Custom cabinets (NK and NSQ) *.
- "Optical" version (without moving glass obstacles) *.



For restrictions on options, please speak to your sales representative.

* Please refer to the respective datasheet for more information.

WORK TO BE PROVIDED BY OTHERS (NOT SUPPLIED)

- Performing the electrical interconnections and connections to the power grid.
- Performing the connections to the access control systems.
- Anchoring the equipment with the appropriate specific floor type hardware.